

62XHD Light Brackets

Page 1 of 2

Please find instructions below on the position to mount the light brackets to 62 XHD machines.

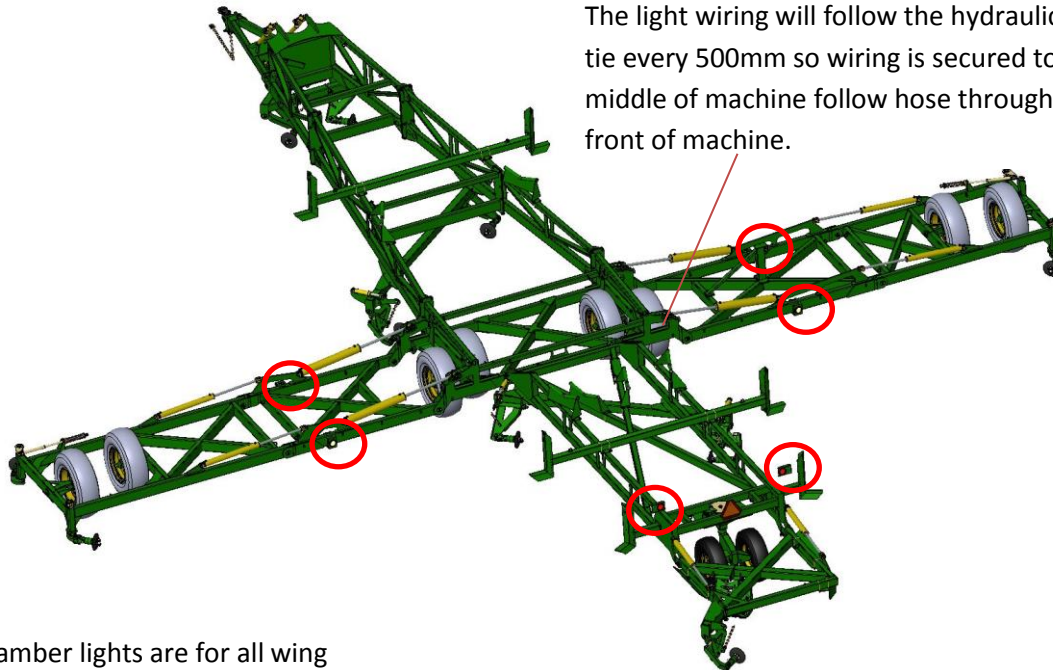

The light wiring will follow the hydraulic hose and zip tie every 500mm so wiring is secured to hose. From middle of machine follow hose through RHS to get to front of machine.

The amber lights are for all wing lights and the two red light are for the rear of the machine

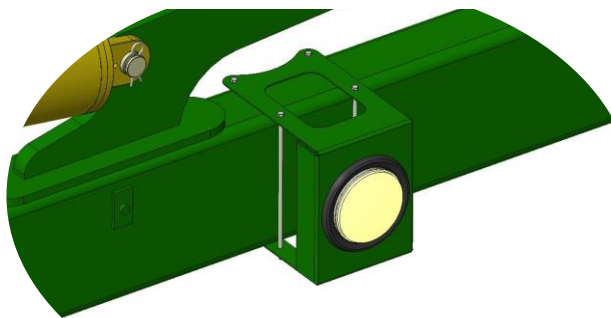

As shown the light bracket wraps around the RHS.

Fasten with M6x220mm Bolts and M6 Nyloc nuts.

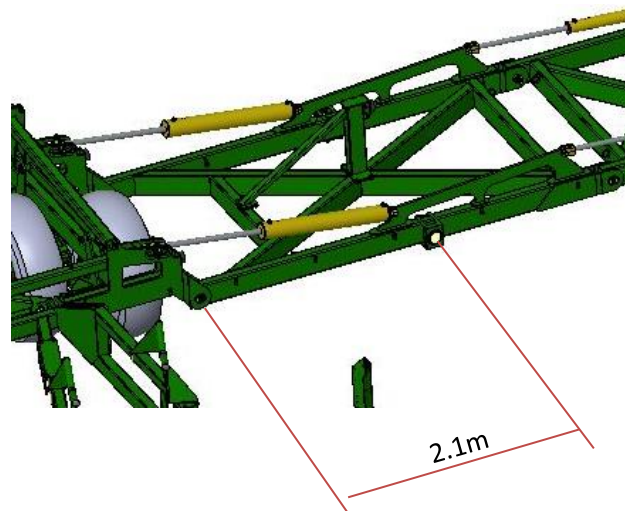

Light brackets are fitted to both front and rear of machines 2.1m in from the pivot pin, as shown here.

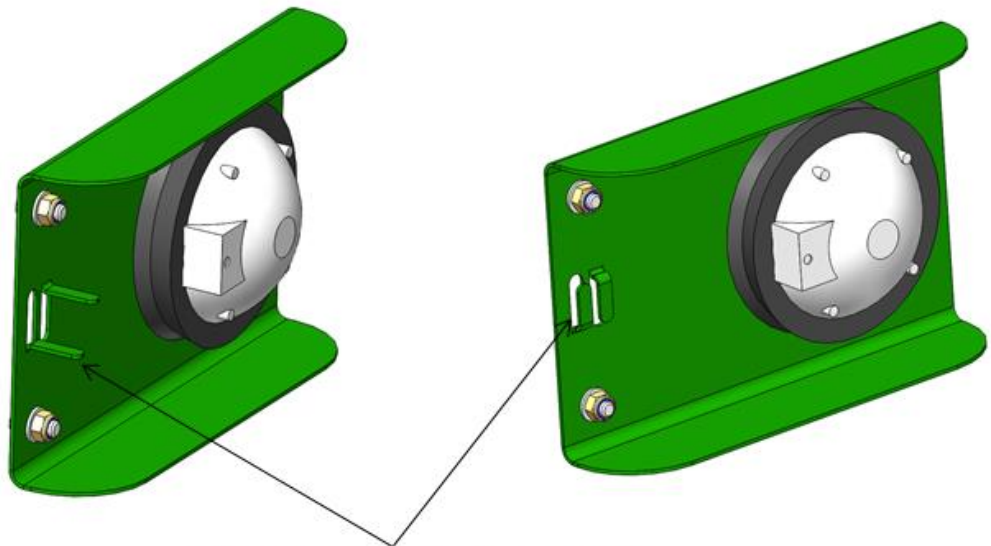

Please ensure to bend tabs up and feed wire through, so the light cable is secure

Mount to chain carrier with 2x M8x20 cup head bolts, Flat washer and Nylon nut

